

32 cm Woofer

32W/4878T11

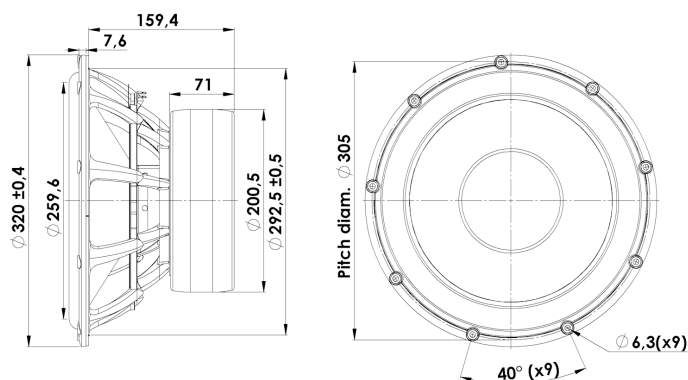

T-S Parameters:

Resonance frequency [fs]	24 Hz
Mechanical Q factor [Qms]	4.25
Electrical Q factor [Qes]	0.22
Total Q factor [Qts]	0.21
Force factor [Bl]	14 Tm
Mechanical resistance [Rms]	3.3 kg/s
Moving mass [Mms]	93 g
Compliance [Cms]	0.47 mm/N
Effective diaph. diameter [D]	260 mm
Effective piston area [Sd]	526 cm ²
Equivalent volume [Vas]	185 l
Sensitivity (2,83V/1m)	95 dB

Mechanical Data:

Voice coil diameter	75 mm
Voice coil height	22 mm
Voice coil layers	2
Gap height	8 mm
Linear excursion	± 7 mm
Max mech. excursion	± 28 mm
Unit weight	9.8 kg
Cabinet Displacement Volume	- l

Electrical Data:

Nominal impedance [Zn]	4 Ω
Minimum impedance [Zmin]	4 Ω
Maximum impedance [Zo]	68 Ω
DC resistance [Re]	3.1 Ω
Voice coil inductance [Le]	0.36 mH

Power Handling:

100h RMS noise test (IEC 18.4)	350 W
Long-term max power (IEC 18.2)	700 W
X-over:	None

Key Features:

- 95 dB Sensitivity @ 2,83V/1m
- Paper sandwich cone
- Coated foam Surround
- Patented Symmetrical Drive motor
- Powerful motor with dual ferrite magnets
- 3" Voice coil, Titanium former and paper reinforced

Recommendations (please see Tech Note):

- Operating frequency range: fs-1500 Hz
- Cabinet volume - closed box: Vbox=22 ltr, f(-3dB)=74 Hz
- Cabinet volume - vented box: Vbox=29 ltr, fb=35 Hz, f(-3dB)=57 Hz

